

Feb. 25, 1941.

W. E. SCARBORO
SURGICAL CAST REMOVER

2,232,733

Filed Feb. 23, 1938

2 Sheets-Sheet 2

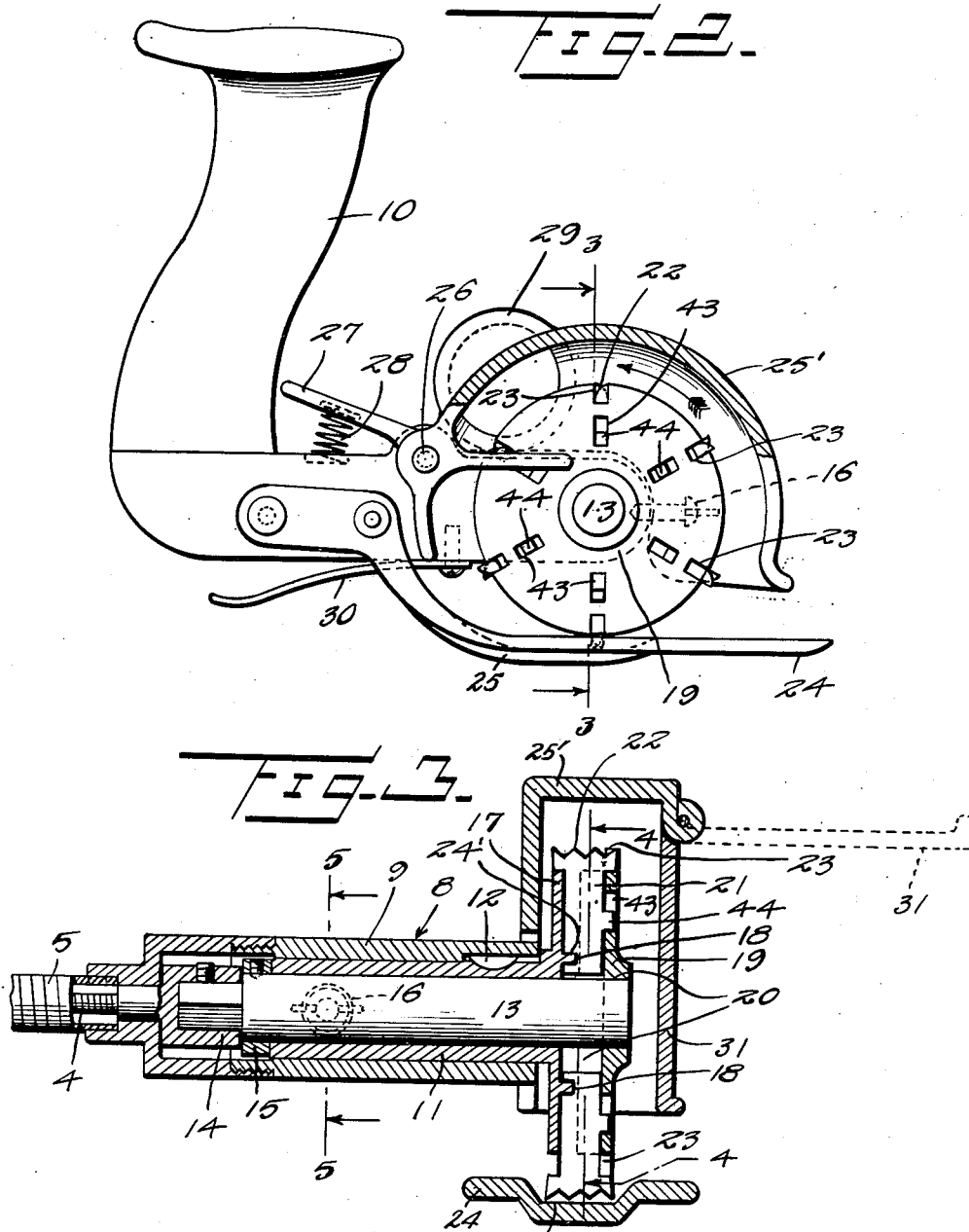

25 William E. Scarboro

INVENTOR

By Victor J. Evans & Co.

ATTORNEYS

UNITED STATES PATENT OFFICE

2,232,733

SURGICAL CAST REMOVER

William E. Scarboro, Savannah, Ga.

Application February 23, 1938, Serial No. 192,100

5 Claims. (Cl. 30-167)

This invention relates to a surgical cast remover and has for the primary object the provision of a portable power driven device of this character which may be conveniently manipulated to sever a cast with ease and quickness and without discomfort and danger of injury to the patient and includes means for carrying off the cuttings leaving the patient and the patient's bed or chair free of said cuttings.

With these and other objects in view, this invention consists in certain novel features of construction, combination and arrangement of parts to be hereinafter more fully described and claimed.

For a complete understanding of my invention, reference is to be had to the following description and accompanying drawings, in which—

Figure 1 is a side elevation illustrating a surgical cast remover constructed in accordance with my invention.

Figure 2 is a fragmentary vertical sectional view showing the cutter and its holder.

Figure 3 is a sectional view taken on line 3-3 of Figure 2.

Figure 4 is a sectional view taken on line 4-4 of Figure 3.

Figure 5 is a sectional view taken on the line 5-5 of Figure 3.

Figure 6 is an enlarged fragmentary sectional view on the line 6-6 of Figure 7, showing a modified form of cutter and mounting therefor.

Figure 7 is a sectional view taken on line 7-7 of Figure 6.

Figure 8 is a sectional view taken on line 8-8 of Figure 6.

Figure 9 is a fragmentary edge view showing the cutting end of the modified form of cutter.

Referring in detail to the drawings, the numeral 1 indicates a stand of a portable nature on which is mounted an electric motor 2 and connected to the latter is a suction fan 3 and a flexible shaft 4 including a flexible housing 5. The fan 3 is driven by the electric motor and its inlet has connected thereto a flexible pipe 6 and connected to the outlet of said fan is a bag or receptacle 7.

The cutter of the present invention is indicated in entirety by the character 8 and consists of a body 9 equipped with a handle 10 and removably mounted therein is a non-rotatable bearing sleeve 11 being keyed to the body 9, as shown at 12. The bearing sleeve rotatably supports a shaft 13 one end of which is shaped to fit a coupler 14 of the flexible shaft 4. Removably mounted on the shaft 13 is a collar 15 which engages

with one end of the bearing sleeve for limiting the sliding movement of the shaft in said sleeve in one direction. The bearing sleeve is further secured against rotation in the body 9 by a set screw 16. A cam disc 17 forms an integral part of the bearing sleeve and has integral therewith a track type cam 18. One end of the shaft 13 projects beyond the cam disc and has secured thereto a cutter head 19 in which is formed a plurality of cutter grooves 20 to slidably receive cutters 21. The grooves 20 extend radially from the shaft 13 positioning the cutters 21 accordingly. The cutting ends of the cutters are in the form of teeth 22 capable of moving wholly within notches 23 formed in the head 19. The cutters or shanks thereof have notches 24' to receive the cam 18 so that as the cutter head rotates with the shaft 13 the cutting ends of the cutters are caused to move inwardly and outwardly of the notches 23 bringing about cleaning of foreign matter from the teeth.

A guard 24 is removably mounted on the handle 10 and underlies the cutter head and is channeled, as shown at 25, to receive the cutting ends as the cutters pass said guard. The cam acts to slide the cutters radially from the shaft as they approach the guard 24 so that the cutting ends of the cutters will be out of the notches 23 into cutting positions as they pass the guard. The cutters on passing the guard are drawn inwardly by the cam or in the direction of the shaft 13 to bring the cutting ends thereof within the notches to remove cuttings from the cutting ends.

A hood 25' is pivotally mounted on the handle 10, as shown at 26, to guard a person from coming in contact with the cutters and includes a finger piece 27 acted on by a spring 28 for urging the hood in the direction of the guard 24. A neck 29 forms an integral part of the hood 25' and has the suction pipe 6 connected thereto. The neck 29 connects the suction pipe to the interior of the hood so that the cuttings gathering within said hood will be taken off by the suction fan 3 and discharged into the container 7.

A resilient leg 30 is secured on the body to ride on the outer surface of a surgical cast during the use of the tool in severing the cast. One side wall of the hood has a hinged section 31 which may be swung laterally of the hood when desiring to remove the shaft and the cutters from the body and the hood.

The guard 24 is of an elongated formation so that its free end is positioned a considerable distance beyond the cutters and is adapted to be inserted under a surgical cast or between said

cast and the patient with the hood 25' bearing against the outer face of the cast. With the electric motor in operation and the device thus positioned in engagement with a cast, the cutters will sever the cast as the cutter in entirety is advanced along the cast without any danger or discomfort to the person having the cast thereon. As the cutters during their rotation with the cutter head are self-cleaned of cuttings by their sliding movement in the cutting head the cuttings will be carried off and collected in the receptacle 7 by the suction fan 8, leaving the patient or person free of cuttings. As the cutter reaches or completes the severance of the cast, the hood 25' under the influence of the spring 28 may move in close proximity to the guard 24 and prevent any part of the person's anatomy from passing between the guard and hood and thereby eliminate any danger of the person becoming injured or cut by the cutter.

Referring to my modified form of invention, as shown in Figures 6 to 9, inclusive, the cutting elements or blades are indicated by the character 32 and have opposite V-shaped guide edges slidable in guide grooves 33 formed in a cutter head 39. The cutter head 39 is somewhat similar in construction to the cutter head 19. The cutting elements 32 each have a cutting end, beveled as shown at 40 to provide a sharp leading edge 40', capable of moving outwardly of the cutter head as the cutter passes the guard 24 and to move inwardly of the cutter head or its periphery thereof when passing from the guard 24 so as to remove cuttings from the cutting end 40. The cutting elements 32 have formed thereon lugs 41 which travel in the cam groove 42 employed in lieu of the cam 18 on the cam plate 17.

The cutter head 19 has slots 43 to slidably receive lugs 44 on the cutters 21 for limiting the sliding movement of the cutters with respect to the head.

What is claimed is:

1. A surgical cast remover comprising a holder, a power driven shaft journaled in said holder, a cutter head secured to said shaft, a plurality of elongated cutting elements rotatable with said cutter head and slidable radially relative thereto, means carried by said holder for effecting the sliding movements of the cutting elements during the rotation of the cutter head, a spring pressed hood pivotally mounted on said holder for enclosing the major portion of the cutter head, and an opposed forwardly projected guard carried by the holder and insertable under the cast to coact with the hood in protecting a person from the cutter, the means for effecting the sliding movements of the cutting elements operating to move the cutting elements sequentially outward of the periphery of the cutter head as they travel towards and longitudinally rearward of said guard and reacting to retract said cutting elements as they move successively away from the guard.

2. A surgical cast remover comprising a holder, a power driven shaft journaled in said holder, a cutter head secured to said shaft, cutting elements rotatable with said cutter head and slidable radially relative thereto, means carried by said holder for effecting sliding movements of the cutting elements during the rotation of the cutter head, a spring pressed hood pivotally mounted on said holder for enclosing the major portion of the cutter head, an opposed forwardly projected guard carried by the holder and insertable under the cast to coact with the hood in protecting a person from the cutter, the means for effecting

the sliding movements of the cutting elements operating to move the cutting elements sequentially outward of the periphery of the cutter head as they travel towards and longitudinally rearward of said guard and reacting to retract said cutting elements as they move successively away from the guard, said hood including a hinged side section capable of being positioned to expose and permit removal of the cutter head and shaft from the holder.

3. The herein described cast remover of the characteristic type comprising a handled holder having a forward lower guard portion insertable under the cast next to the part of the body on which the cast is applied and also having a protective hood overhanging the guard portion and mounted for movement toward and from said guard portion with provision for urging it towards the guard portion and yieldably holding it against the outside of the interposed portion of the cast, and rotary cutter means carried by said holder in working relation between said guard portion and protective hood, said means comprising a circular cutter head, a plurality of reciprocatory cutters slidably mounted on said cutter head whereby their cutting ends are movable radially inward and outward of the periphery of the cutter head, and means for effecting reciprocation of the cutters during rotation of the cutter head, said means causing sequential outward movement of the cutters as the peripheral portions of the cutter head carrying the respective cutters travel towards and longitudinally rearward of the guard portion of the holder and reacting to retract the outwardly moved cutters in succession as the peripheral portions of the cutter head where the respective cutters are located travel away from the guard portion of the holder.

4. In a cast remover of the rotary cutter type and including a handled holder having a main body carrying a forwardly projected lower guard portion insertable under the cast next to the part of the body on which the cast is applied and a protective hood overhanging the guard portion with movement towards and from the same and having provision for normally urging the hood in the direction towards the guard portion and yieldably holding it against the outside of the interposed portion of the cast, the main body having an axially bored lateral extension, a stationary bearing member mounted in the bore of said lateral extension but held against rotation therein, said bearing member having a cam head located within the protective hood, a driving shaft mounted rotatably in an axial bore provided therefor in said bearing member, a circular cutter head fixed on said driving shaft so as to rotate therewith and being located in opposed working relation to the cam head of said bearing member, a plurality of elongated radial cutter elements slidably mounted, cutting end outward, on said cutter head for reciprocation in the direction of their longitudinal axes and in an interposed relation between the cutter head and said cam head, said cutter elements having a coactive interengagement with the cam portion of the cam head, whereby, upon rotation of the cutter head the cutter elements are reciprocated, the relative contour of the cam portion being such that the cutter elements are moved sequentially to project their cutting ends to an operating position beyond the periphery of the cutter head as the adjacent peripheral portions of the

5 cutter head where the respective cutters are located travel toward and longitudinally rearward of said guard portion and said cutter elements are retracted as they leave the guard portion in succession.

5. The structure set forth in claim 4 with the guard portion further described as extending with its major portion substantially tangential to the

periphery of the cutter head and having a portion rearward of its forward end and in the region immediately beneath the cutter head formed with a longitudinal depression for clearance of the projected cutter elements traveling in working relation thereto. 5

WILLIAM E. SCARBORO.